

CryoAdvance Configuration/Information/Dimensions

Date:
8/25/2021

System/Product Description

Basic description of CryoAdvance:

- \varnothing 50mm or \varnothing 100mm ID radiation shield/sample space
- Bare platform with options for radiation shield/vacuum housings and sample mounting
- Mounts to table parallel or 45° (Inch or Metric)
- Air cooled compressor
- Approx weight: 29Kg
- See Options for more detail

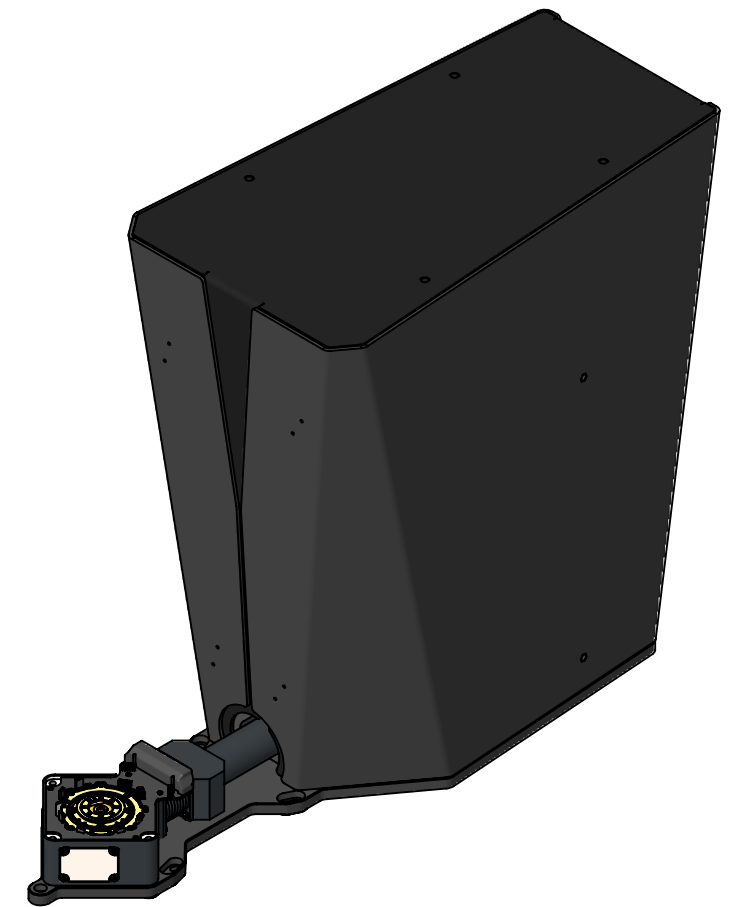
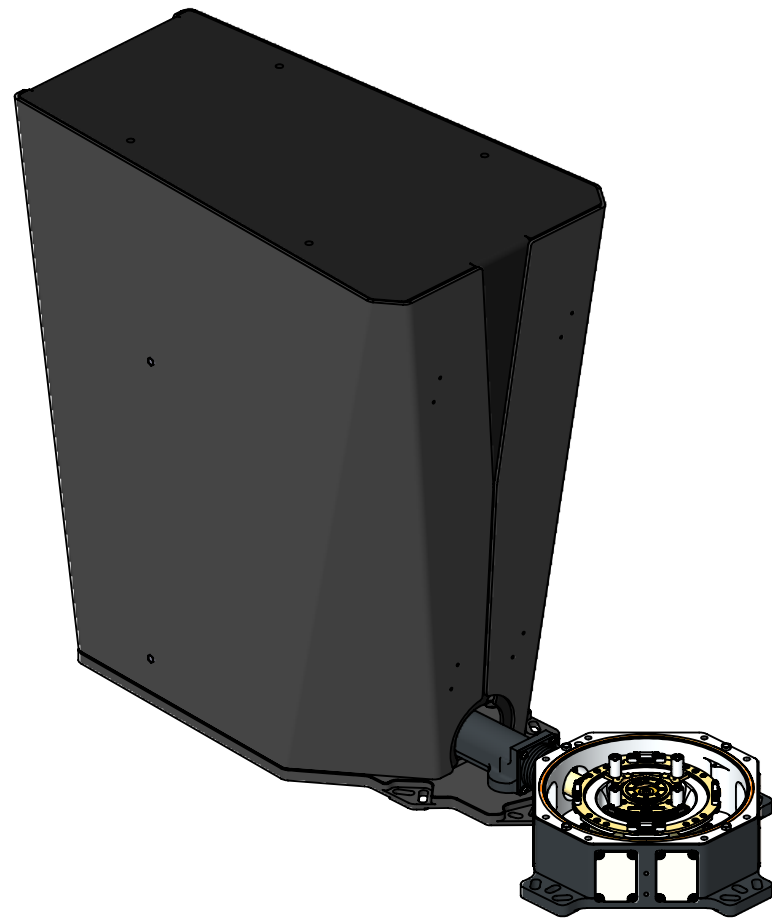

Overall Dimensions

A

∅ 50mm

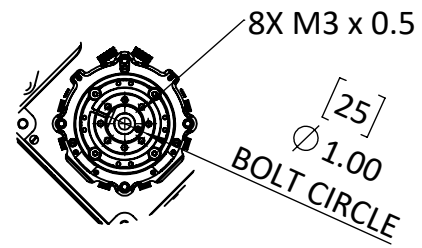

DETAIL A
SCALE 1 : 4

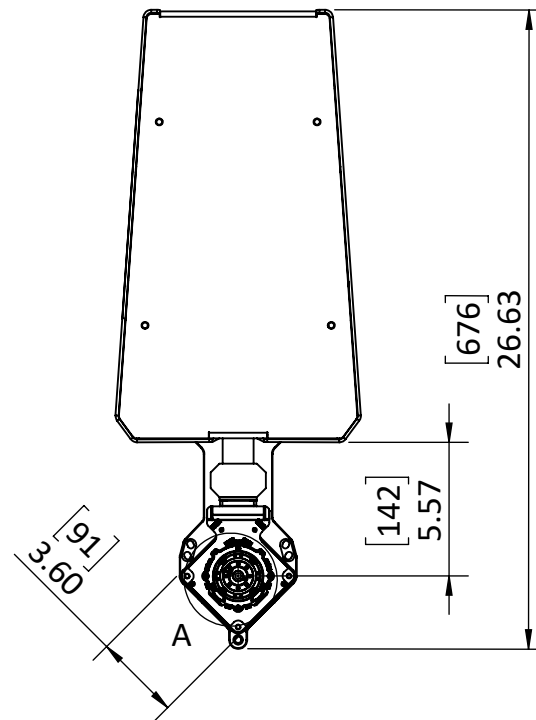

B

C

D

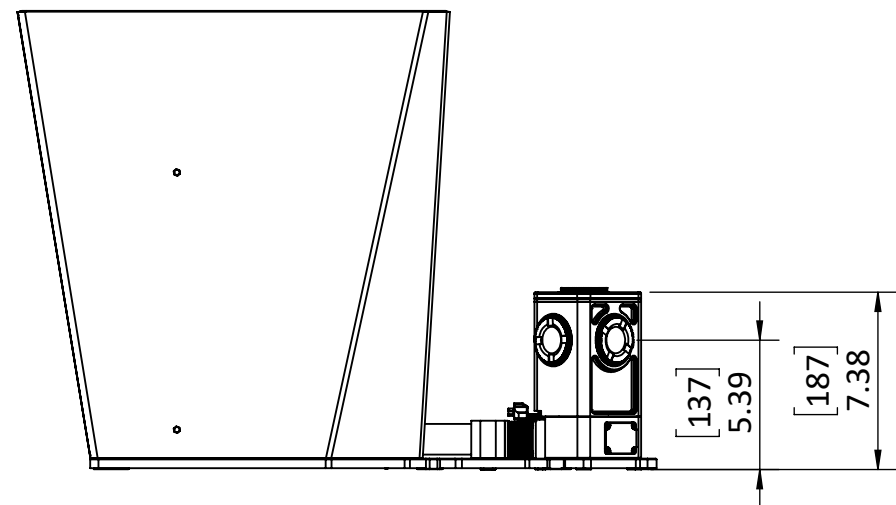

WITH STANDARD UPPER HOUSING,
4405-565-00

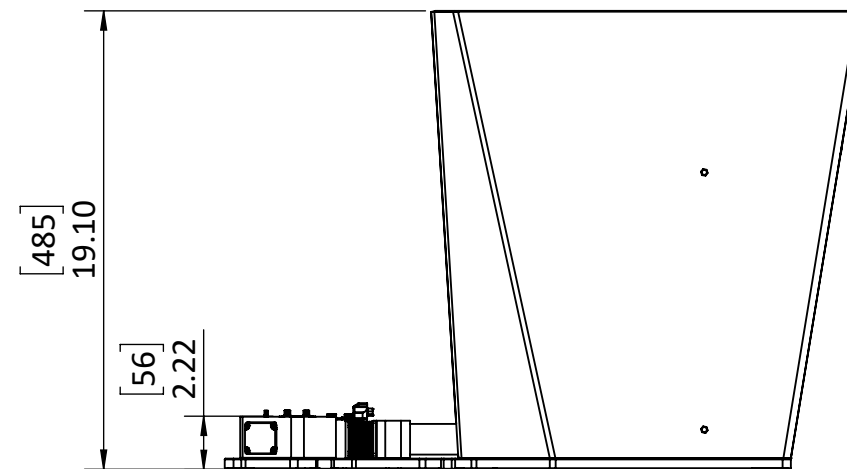
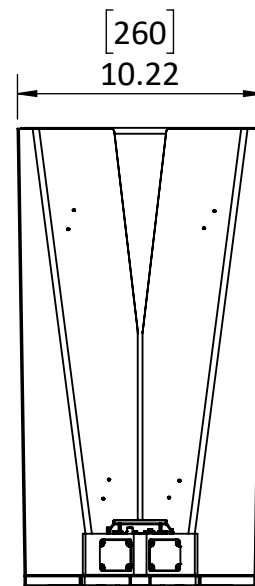

A

B

C

D

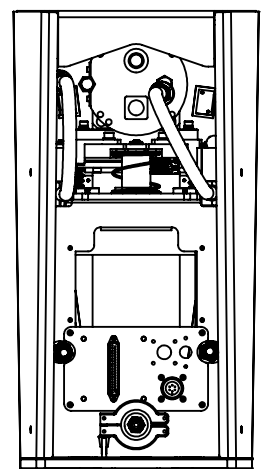
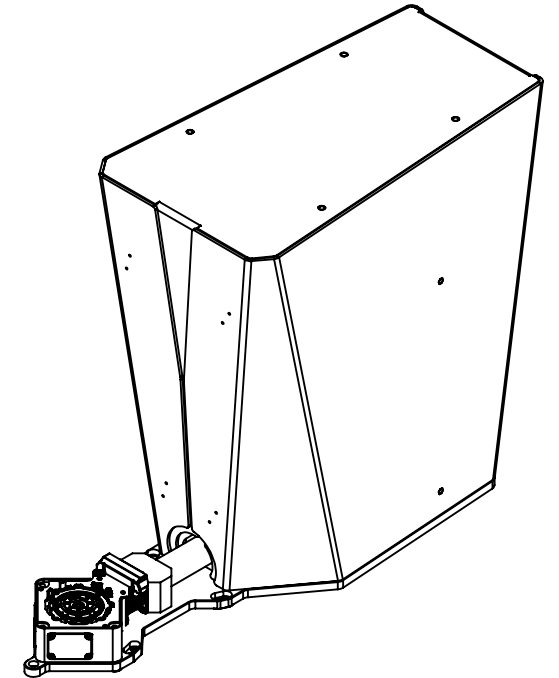

1

2

1

2

Overall Dimensions

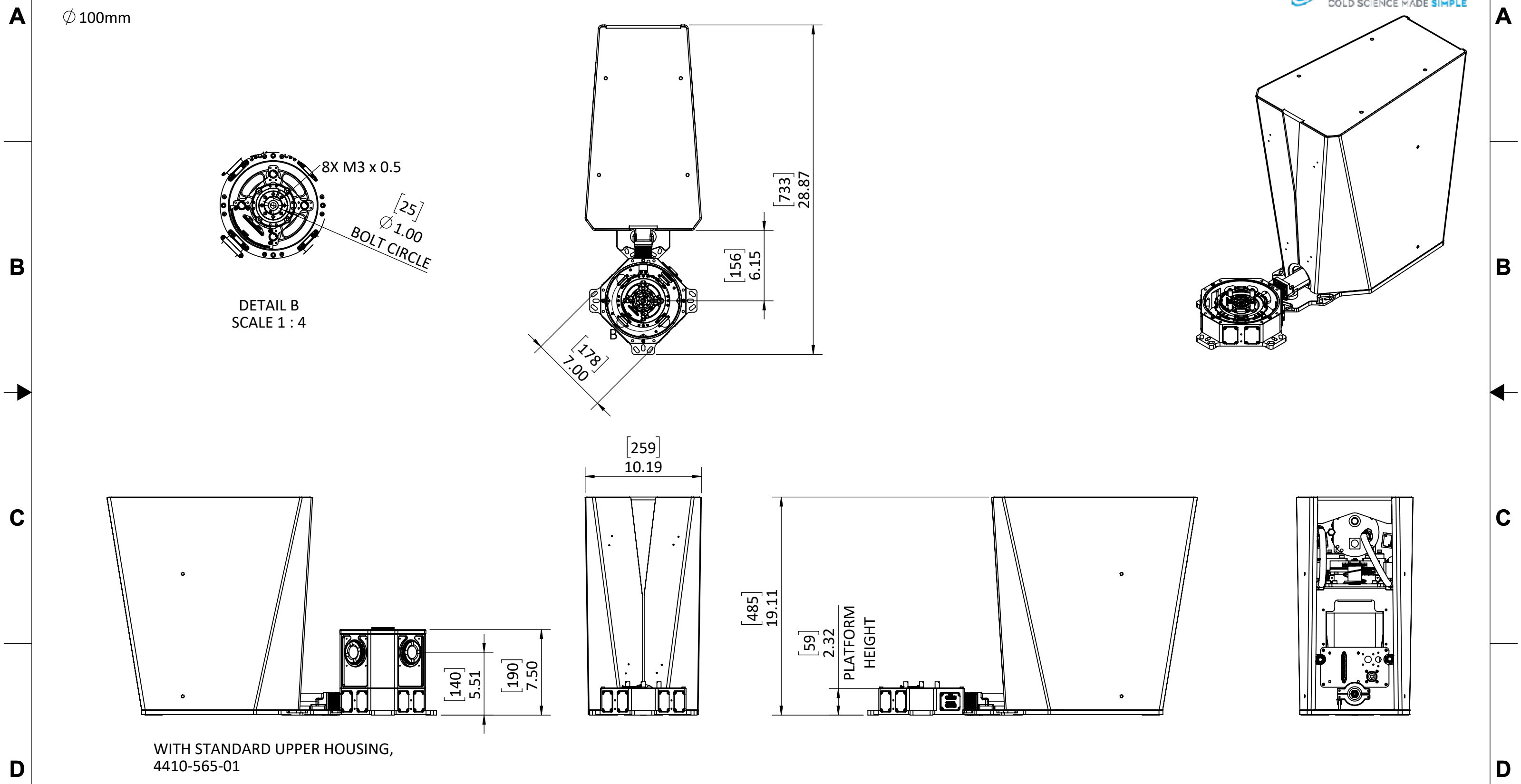

WITH STANDARD UPPER HOUSING,
4410-565-01