



easyXES150



- Rapid transmission mode XAFS
- Proven research-quality performance
- High throughput for sample characterization or product testing
- Suitable for in situ R&D in electrical energy storage, catalysis, etc.
- Virtual beamline appearance with fully supported, easy to use software
- Run multiple samples or sample conditions with scripted operations
- Easy integration with ancillary equipment for control of sample conditions.
- Extremely low maintenance

PRODUCT SPECIFICATIONS

Energy Range	Standard operations from 4.5-12 keV*. Capabilities up to 19 keV with reduced throughput. *Depends on selection of crystal analyzers	Reproducibility	<50 meV energy scale drift with no monochromator realignment
Angular Range	55-85 degrees Bragg angle	Analyzer Crystals	Spherically-bent Si or Ge analyzers with 10-cm diameter and 50-cm radius of curvature
Resolving Power (E/ΔE)	typ. >2800 (i.e. 2.5 eV @ 7 keV) for Bragg ≥ 80deg	Analyzer Alignment	Pre-aligned with "clock angle protocol" (pat. pend.) for rapid (~5 min) and reproducible swapping
Flux (XAFS)	Typical monochromatic flux of >100,000/s when working near backscatter for 7-9 keV	Detector	Large-area SDD with 150-300 eV resolution for rejection of background and harmonics
Flux (XES)	Core-hole generation rate of ~10 ¹² /s for concentrated samples.	Sample Turret	7-position, motorized sample wheel available for programmable XAFS studies
X-Ray Source (XAFS)	100-W XRF-style, air-cooled tube with W/Pd anode. 35 kV maximum accelerating potential. 4 mA maximum filament current.	Software	· LabVIEW-based GUI for calibration, regular operations, scripted scans and easy integration with external equipment. Python-based GUI for data processing for final spectra.
X-Ray Source (XES)	100-W XRF-style, air-cooled tube with W/Pd anode. 35 kV maximum accelerating potential. 4 mA maximum filament current.	Utility Requirements	· Helium gas for flight-path · 110-220 V/50-60 Hz, 1000-W for spectrometer drive and electronics · 110-220 V/50-60 Hz, 300-W for control computer



easyXES150

Dimensions

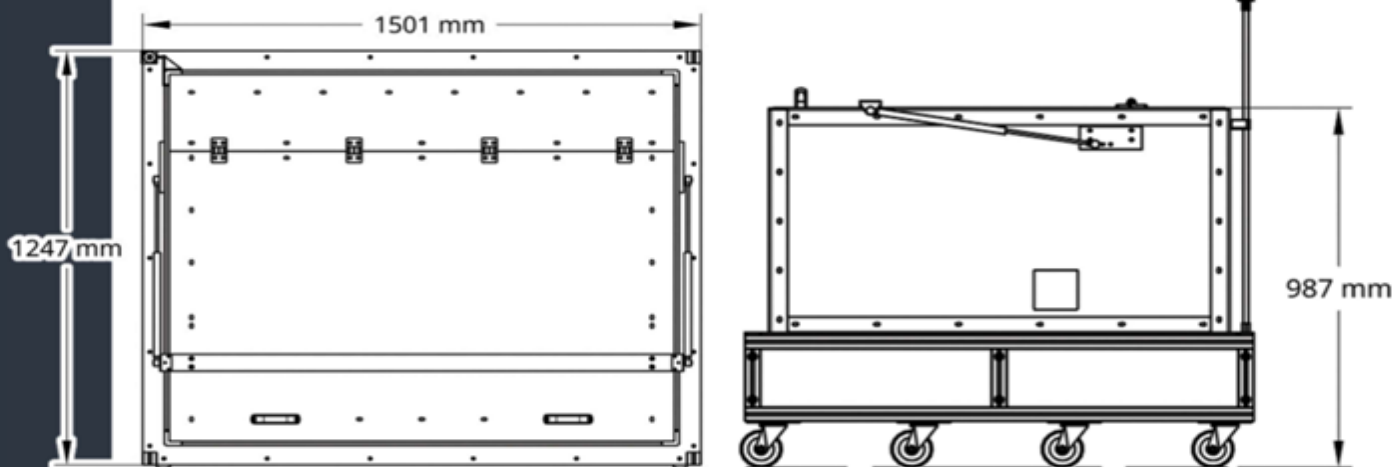

Example Data - XAFS

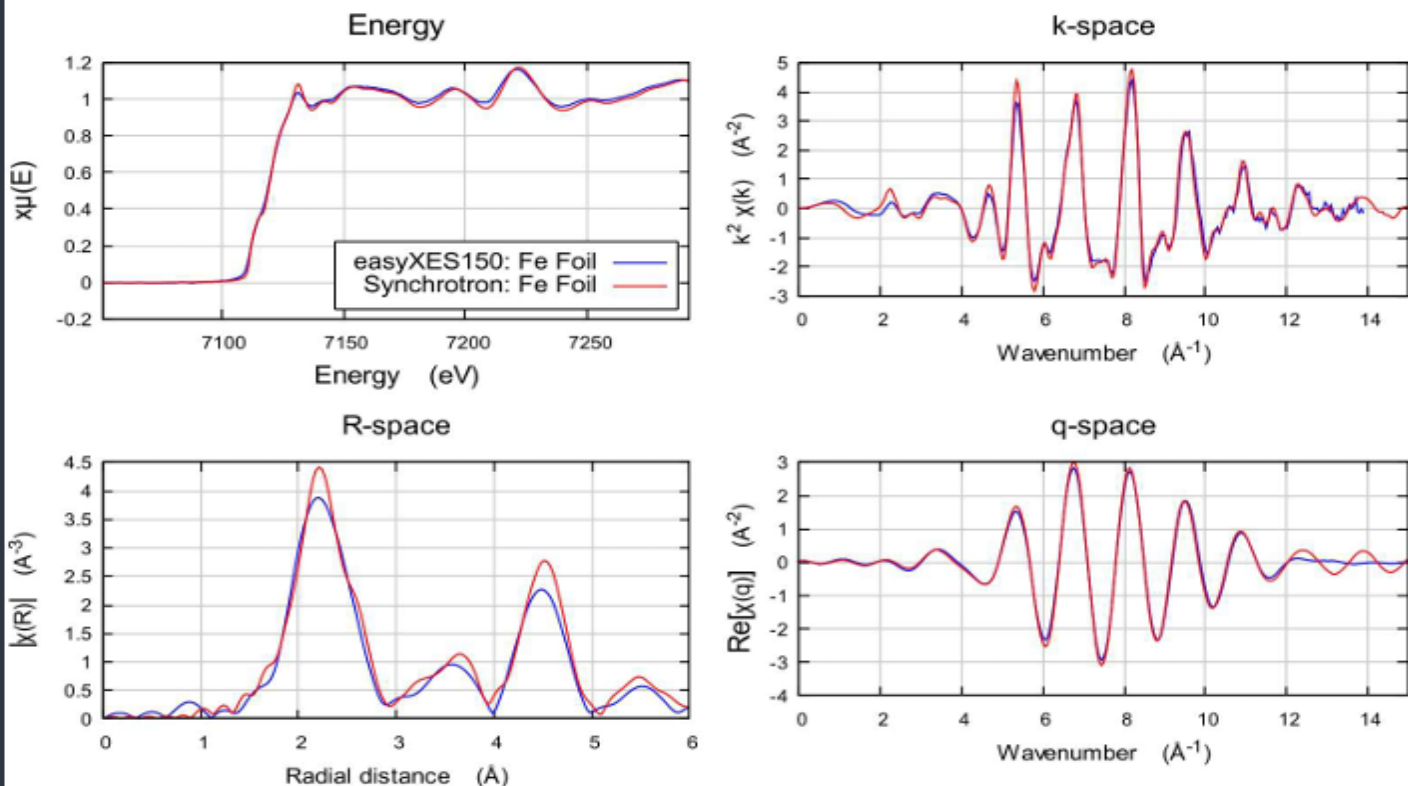

XES (high-resolution XRF)

Research-quality x-ray emission spectroscopy (XES) measurements in synchrotron-comparable integration times.

Laboratory XES may facilitate insights into oxidation state, spin state, and ligand identity, even for very dilute samples.

