



Application Note

High Power Heater Application Cryogenic Temperature Controller with Extended Heater Power

- Several hundred watt MAX heater power with a controller
- Fully controllable with new or existing Lake Shore Model 321, 330, 331, DRC-91CA, DRC-93CA, and 340 Temperature Controllers.
- Variable DC current output
- Heater output is isolated from the measurement circuitry
- High gain and zeroable offset
- Programmable overvoltage protector

What is the Extended Heater Power?

The Cryogenic Temperature Controller with Extended Heater Power is a hardware application in which a Lake Shore temperature controller and a voltage-controlled current source (VCCS) can be used in conjunction to allow the user to control a variety of cooling systems while maintaining up to several hundred watts of heater power. It can be used with Lake Shore's Model 321, 330, 331, DRC-91CA, DRC-93CA, and 340 Temperature Controllers. Any sensor compatible with these controllers can be used.

Extended heater power is the ideal choice for the user who either has an existing LS controller or is interested in a new unit and requires a heater capable of supplying several hundred watts of power. This will allow the user to easily control their system at and well above cryogenic temperatures.

How Extended Heater Power operates.

1. The user must first set the LS temperature controller's heater current output on the lowest level. This achieves the highest resolution.
2. Next, the user places a programming resistor across the LS controller output leads. The value of the resistor should be equal to maximum input voltage for the VCCS (Typically 10 Volts) divided by maximum current output level of the LS controller. (Note: This voltage should be maximized, but is limited to the VCCS input voltage and the controller compliance voltage.)
3. The voltage signal is then supplied as the input control voltage for the VCCS.
4. As the LS controller heater output current decreases or increases to control, the VCCS output heater current responds respectively and the system temperature is controlled.

Example 1: For use with single control channel (Models 321, 330, DRC-91CA, and DRC-93CA) and a Kepco ATE 100-2.5M:

1. Lake Shore's Model 330 Temperature Controller can be set on three current levels: 1A, 0.3A, and 0.1A. The maximum current level is 1A, and the lowest current setting is 0.1A. By choosing 0.1A, the current output will vary from 0 to 0.1A, while achieving maximum resolution.
2. Since the input voltage control range for the Kepco ATE 100-2.5M is 0 to 10 volts, a programming resistor is placed across the leads of the LS controller. The value of the resistor, $R_{pgm} = V / I$ or $R_{pgm} = 10 \text{ volts} / 0.1A = 100 \text{ ohms}$. With this setup, as the Model 330 varies its output current between 0 and 0.1A, the corresponding voltage will vary between 0 and 10 volts. Note: The power a resistor will dissipate is based on the current and resistance or $P_d = I^2 * R_{pgm}$. The user selected resistor should be able to handle at least this power rating. For this example, $P_d = 0.1A^2 * 100 \text{ ohms} = 1 \text{ watt}$.
3. This 0 to 10 volt signal is then applied as the input control voltage of the Kepco.
4. As the Kepco input voltage ranges from 0 to 10 volts, the output current will vary correspondingly from 0 to 2.5A. This current, in conjunction with $R_{htr} = 40 \text{ ohm}$ heater load will provide heater power between 0 and 250 watts.

Example 2: Two of the possible options are given for use with 2 control loops (Models 331 and 340) and a Kepco ATE 100-2.5M:

Option 1: 2 channels required with high power (≤ 250 watts) on the first and low power (≤ 1 watt) on the second:

1. Lake Shore's Model 340 Temperature Controller Channel 1 can be set on four current levels: 2A, 1A, 0.5A, and 0.25A. The maximum current level is 2A, and the lowest current setting is 0.0025A. By choosing 0.0025A, the current output will vary from 0 to 0.0025A, while achieving maximum resolution.
2. Since the input voltage control range for the Kepco is 0 to 10 volts, a programming resistor is placed across the leads of the LS controller. The value of the resistor, $R_{pgm} = V / I$ or $R_{pgm} = 10 \text{ volts} / 0.0025A = 4000 \text{ ohms}$. With this setup, as the Model 340 varies its output current between 0 and 0.0025A, the corresponding voltage will vary between 0 and 10 volts. Note: The power a resistor will dissipate is based on the current and resistance or $P_d = I^2 * R_{pgm}$. The user selected resistor should be able to handle at least this power rating. For this example, $P_d = 0.0025A^2 * 4000 \text{ ohms} = 0.025 \text{ watts}$.
3. This 0 to 10 volt signal is then applied as the input control voltage for the Kepco.
4. As the Kepco input voltage ranges from 0 to 10 volts, the output current will vary correspondingly from 0 - 2.5A. This current, in conjunction with $R_{htr} = 40 \text{ ohm}$ heater load will provide heater power between 0 and 250 watts.
5. The 2nd control channel is used with a 100 ohm resistor to provide 1 watt of heating power.



Option 2: 2 channels required with high power (<=100watts) on the first and high power (<=250 watts) on the second:

1. Lake Shore's Model 340 Temperature Controller Channel 1 is set to the maximum current level of 2A. This current, in conjunction with Rhtr = 25 ohm heater is used to produce 100 watts of heating power.
2. The second control channel output voltage varies between 0 and 10 volts. This 0 to 10 volt signal is applied as the input control voltage for the Kepco.
3. As the Kepco input voltage ranges from 0 to 10 volts, the output current will vary correspondingly from 0 - 2.5A. This current, in conjunction with Rhtr = 40 ohm heater load will provide heater power between 0 and 250 watts.

Lake Shore Controller Model	Heater/Control Output	Control Output Range	Rpgm.(Across output of controller.)	Power in Rpgm.	Rhtr(Across output of Kepco.)	MAX power supplied by Kepco ATE 100-2.5M.
321	1	0-0.316A	31.6 ohms	3.16 watts	40 ohms	250 watts
330	1	0-0.1A	100 ohms	1 watt	40 ohms	250 watts
DRC-91CA	1	0-0.03A	333.3 ohms	0.3 watts	40 ohms	250 watts
DRC-93CA	1	0-0.01A	1000 ohms	0.1 watts	40 ohms	250 watts
331	Loop 1	0-0.1A	100 ohms	1 watt	40 ohms	250 watts
	Loop 2	0-10V	Not Applicable	Not Applicable	40 ohms	250 watts
340 Option 1:	Loop 1	0-0.0025A	4000 ohms	0.025 watts	40 ohms	250 watts
	Loop 2	0-10V	Not Applicable	Not Applicable	100 ohms (Out of 340)	1 watt
Option 2:	Loop 1	0-2A	Not Applicable	Not Applicable	25 ohms (Out of 340)	100 watts
	Loop 2	0-10V	Not Applicable	Not Applicable	40 ohms	250 watts

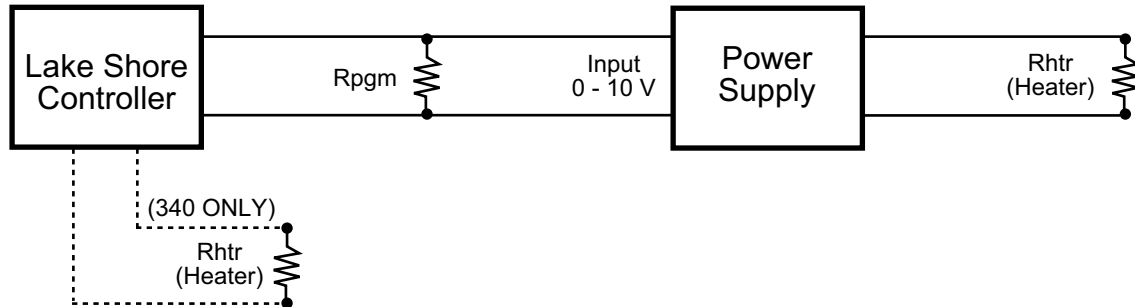

Control:

Number of inputs: One
Input voltage range: 0 to 10 volts DC
Control type: Remote analog current control

Analog Output:

Type: Variable DC current source
Range: 0-100 volts, 0-2.5 Amps.
Load: 0-2.5A at 40 Ohms, 250 watts

Front Panel:

Display: 2 Analog gauges, 3%
Units: Volts, Amps

General:

Ambient temperature range: 0-55°C for 0-100% of rating, 65°C for 0-90% of rating
Power: 110, 120, 220, 240 VAC; 47-65 Hz
Enclosure type: Half rack
Size: 132.6 mm High x 211.9 mm Wide x 435.5 mm Deep (5 7/32" x 8 11/32" x 17 9/64")
Weight: 43 lbs. (19.5 kg.)